

# **LEADER FOX**



## Electric Bicycle Operating Instructions

Under the law, the dealer is obliged to attach the LEADER FOX Electric Bicycle Operating Instructions to every product



**E – BIKE** POWER RIDE

**Altar**  
**Bend**



# Introduction

Dear users,

Please read carefully all the information regarding your E-LF product to ensure optimal functioning of your e-bike. The following text containing a comprehensive description will provide you with information on all aspects and details (including installation, setting up and general use of the display) regarding the use of our display. This instruction document will also help you solve potential problems and failures.

## What is an electric bicycle?

Electric bicycle is a conventional bicycle with an electric drive added to assist the rider. The motor function is actuated by pedalling, which is scanned by a special sensor installed in the pedal hub. Therefore, you have to keep pedalling on an e-bike, the motor is there only to help you. You can set an electric bicycle in motion also using a control button or an accelerator but only up to the maximum permitted speed of 6 KMPH (e.g. for walk assistance). The maximum speed of an e-bike with motor assistance is 25 KMPH, with a 10% tolerance (when this speed limit is reached, the motor switches off and you need to pedal just like with a regular bicycle). When your battery runs out of power or your motor is off, you can ride your electric bicycle as a conventional bike, without any resistance at all.

From the point of view of the Road Traffic Act, an electric bicycle whose features conform to European standard EN 15194-1 is regarded as a regular bicycle, i.e. you can ride on bike trails, do not need a driver's license and a helmet is mandatory only up to 18 years of age.

## Description



## Factors influencing the range

- 1. Rolling resistance of the tyres.** Leader Fox e-bikes are fitted with tyres with low rolling resistance and increased resistance to puncture. It is also important that the tyres are inflated properly. Therefore, if the tyres of your electric bicycle are underinflated, the range will decrease.
- 2. Weight of the electric bicycle.** The lower weight of the electric bicycle, the greater the range.
- 3. Battery status.** It depends on whether the battery was fully charged before your trip. It is also to be expected that the higher the number of discharge cycles the battery has undergone, the smaller capacity it has.
- 4. Profile and surface of the track.** The higher the elevation difference and the steeper hills you negotiate and the worse surface, the shorter the range.
- 5. Riding mode.** It depends on which of the three riding modes you have set.
- 6. Continuity of riding.** The more braking and acceleration, the shorter the range.
- 7. Air resistance.** For example, it depends on whether we ride a bicycle with low frame and sitting upright or whether we ride sporty bicycle with seat set to the same height as the handlebars.
- 8. Wind strength.** The stronger the wind we have back, the longer the range and vice versa.
- 9. Weight of the rider and load.** The greater the weight, the shorter the range.
- 10. External temperature.** The lower the temperature, the less battery capacity can be used while riding.

# Electric set

The system uses monitoring of torque, monitoring of speed of the pedal assist system and monitoring of real speed of wheels.

The system uses a dual protection feedback for measuring the speed signal to ensure safety and reliability of the system.

It has high starting torque, maximum torque of over 80 Nm, suitable especially for riding uphill.

It is highly efficient with low power consumption, long range, low noise levels, and smooth operation.

## **Description and scope of operation:**

The motor unit works properly under the following operating conditions:

Temperature range -20 + 55°C

Relative humidity -15 -95% RH

Maximum torque -> 80

Weight -3.9Kg

Noise -<55 dB

Dustproof/ waterproof -IP66

Certified -CE ROHS/ EN14766/ EN114764/ REACH

Front and rear light -DC 400mA/6V

## **Description of the power unit is placed on the cover and shows the following information:**

MM G33.350 -name of motor unit

1401 -date of manufacture e.g.: January 2014 in this case

0001 -is so-called serial number which ranges between 0000 and 9999, 0001 is for example the serial number

of the first manufactured motor.

36V -nominal voltage

250W -nominal motor power

Dimensions of the power unit:

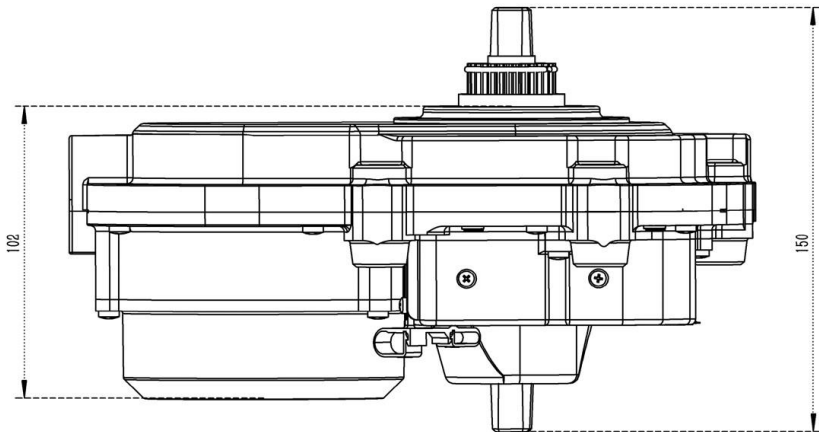
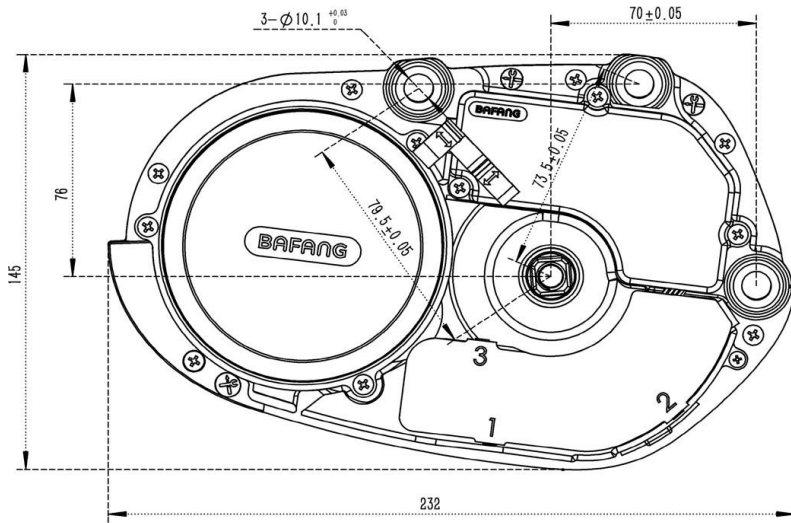

## Basic safety recommendations

### Riding safety:

While riding, pay only as much attention to the bicycle settings and display as not to jeopardize your safety.

Before riding, check that wheels have been securely fitted in the frame and fork, since their incorrect installation can cause serious injury.

When riding the electric bicycle, you should be fully familiar with its behaviour and control, otherwise it could result in serious injury.

If you ride in poor visibility conditions or at night, use the lights.

### Battery:

DO NOT use the battery with other devices.

DO NOT dismantle or modify the battery.

DO NOT connect positive and negative poles of the battery with a metal object.

DO NOT immerse the battery in water.

DO NOT throw battery into fire.



### Charging set



**Charger:**

DONOT dismantle or modify the charger  
DO NOT use to charge other batteries.  
AVOID shocks and contact with water.  
DO NOT touch the charger with wet hands.  
KEEP the charger away from children and animals.  
DO NOT cover the charger nor place any objects on it.  
DO NOT pull the cable when disconnecting the charger, ALWAYS pull the plug.  
DO NOT use the charger if it is clearly damaged.

**Basic maintenance and instruction guide for the use of electric bicycle:**

Always remove the battery if you are going to manipulate with the cables or replace any part of the electric bicycle, since there is a danger of injury by electrical current.

If you feel that the electric motor or any of its parts might have gotten loose, make sure that the nuts are properly tightened or follow further information in the user guidebook.

The chain should be regularly cleaned by cleaning agents for this purpose. Do not use alkaline or acidic cleaners to remove rust or dirt. These cleaners will damage the chain.

Use the battery charger only for its intended purpose. If the charger or any of its parts is broken, do not use it as this could cause injury.

Electric bicycle is not intended to be used by people with lowered physical, sensory or mental capacities or people lacking experience and knowledge required to use the product.

Electric bicycle is not intended for use by children.

Do not attempt to repair the electric motor system, as this can cause its damage and malfunction.

The bicycle electric system is designed to be fully waterproof and can therefore be used even in harsh weather conditions or in wet environment. You should, however, avoid its direct dipping in water.

Do not use high pressure water (WAP) to clean the bicycle. If water gets into the system, this can cause damage or corrosion.

When transporting the bicycle on a vehicle in rainy or wet weather, remove the battery and store it in a dry place.

Handle the bicycle carefully and avoid shocks.

To clean the battery and all the plastic parts of the system, use a well wrung out, damp cloth.

# Battery

## **Battery charging and maintenance:**

Charge the battery in a dry environment to avoid short-circuit damage.

Charge the battery to at least 60% of capacity once every 3 months even when the bicycle is not used.

Do not cover the battery or the charger.

Do not leave the battery constantly connected to the power source.

Use the charger only to charge the battery.

Do not use the battery for other appliances. It has been made specifically for this model.

Do not disassemble or modify the battery pack.

Do not throw the battery into fire or expose it to extreme temperatures.

Recharging time from zero to 100 % is 4-6 hours.

If the battery is not charged after 6 hours, disconnect the battery and abort charging. The battery may overheat, crack or ignite.

In case of liquid from battery getting into your eyes or in contact with your skin, flush with clean water immediately and seek medical help. Otherwise, this can result in serious injury.

Do not use the battery if it is clearly damaged, it can result in its destruction.

Do not attempt to deform or otherwise tamper with the battery.

Do not attempt to solder a direct connection of battery and cables, it could result in cracks or ignition of the battery.

Do not use the battery near fire or source of direct heat, do not throw the battery into fire, as this can cause cracks or ignition of the battery.

Do not expose the battery to shocks or vibration.

Do not insert metal objects into the power outlet, as this could cause short-circuit, overheating, crack or ignition of the battery.

KEEP the charger away from children and animals.

## **Charging:**

The battery is the most expensive part of an electric bicycle; therefore, pay increased attention during handling, charging and storage. The battery is sensitive to precise charging. Therefore, it is necessary to charge Li-Ion rechargeable batteries using only a charger supplied by us. Connect the charger to 220-240 V power outlet. 5A protected circuit is sufficient. The charger will automatically suspend charging when full capacity of all cells is reached.

We recommend discharging the battery in full after each ride to ensure that your battery will be up to its full capacity for your next ride. Charging the battery may last 1 to 5 hours depending on the condition of the battery cells. Charge it exclusively in covered dry areas (moisture and dripping water can damage the charger) at a temperature of 5 to 40°C.

The charging process is indicated by a red glowing LED. It will turn green when the battery is charged and the charging process is complete. The battery contains a charge-monitoring indicator (when the charge indicator button is pressed, the light indicator will come on). Always switch off the battery when finished riding the bike.

## **Normal battery behaviour:**

If the motor stops running smoothly and switches to intermittent operation, it could be a sign of low battery capacity. In that case switch off the electric drive system and continue without motor assistance,



as if riding a conventional bicycle.

Battery warming is normal and does not indicate any defect. The battery is protected by a temperature sensor and switches off automatically in case of excessive overheating. Wait until the battery cools down to its normal operating temperature and then ride on.

If you feel your total battery capacity has dropped, it could be caused by charging or operation in suboptimal climatic conditions. Carry out 3 full charging cycles. Fully discharge the battery while riding and then charge to its full capacity at room temperature.

If the charge indicator shows that the battery is discharged, there is still a minimum voltage level in it which protects it against damage but is not enough to power the electric bicycle. Recharge the battery as soon as possible. Never leave the battery fully discharged, it could result in its damage.

**Proper care of the battery prolongs its life.**

# LCD display

## Product:

Intelligent LCD display APT TFT850C

## Supplier:

Tianjin APT Development Cop., Ltd.

## Electrical parameters:

Battery supply 36V

Rated operating current 40mA

Max operating current 100 mA

Off leakage current < 1 uA

Maxoutput current to controller 100mA

Operating temperature -20 ~ 70 °C

Storage temperature -30 ~ 80 °C

## Dimensions and materials:

High-contrast TFT colorful display.

Prodcut shell is ABS, transparent window is made withhigh strength Acrylic.

Can be used up to -20°C.

CE / IP65 water proof / ROHS.



**TFT screen instruction:**

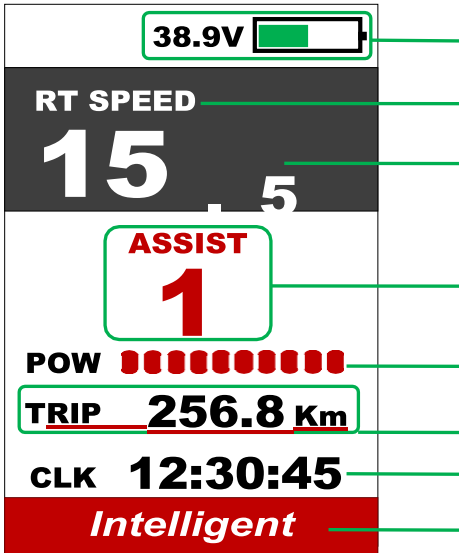

Battery indicator of capacity

RT Speed –indicator of speed mode(RT, MAX, AVG)

15.5 – speed indicator

1 assist –level PAS, 0 (off) 7 (max. assist)

Power – performance

Trip –indicator of mileage mode

CLK - clock

**Maximal range:**

Maximal range is set with fully charge battery and flat terrain and little bit of headwind. Average range is calculated with ideal set of the assist and slightly hilly terrain.

# Controller

Controller description:

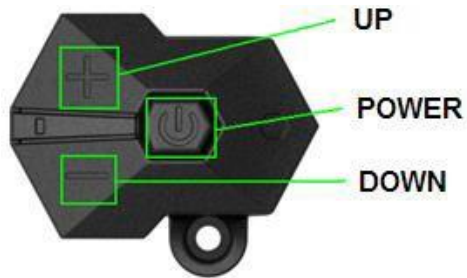

# Assembly instructions

## Display assembly:

Please pay attention to the tightening torque of screws. Damage caused by excessive tightening torque or incorrect assembly / disassembly is not covered by warranty.

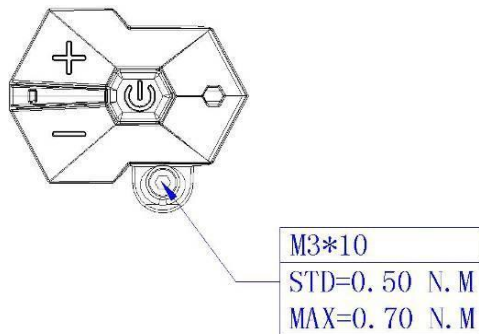
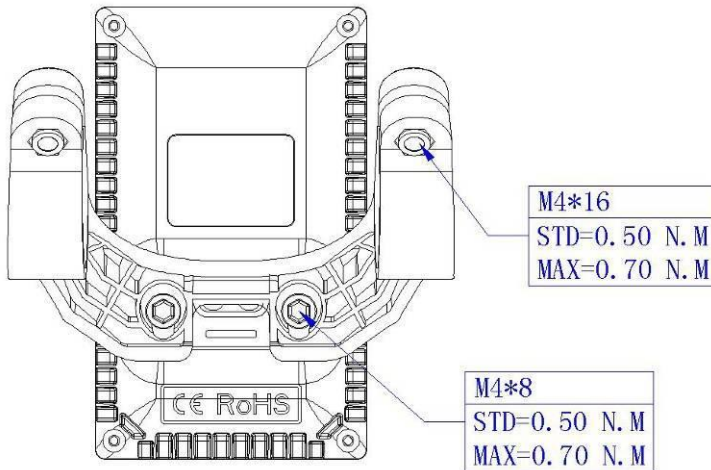

**Speed measuring sensor settings:**

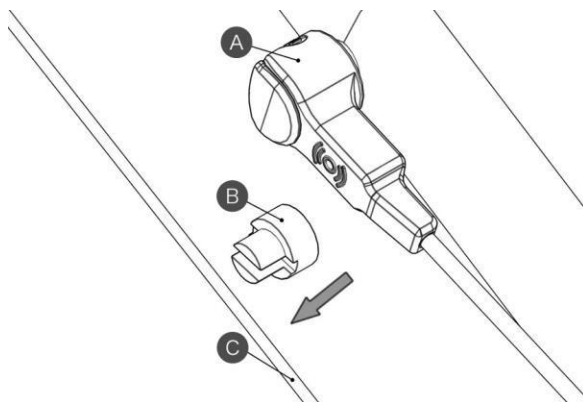

A –speed sensor

B –magnetic unit

C –wire spoke

D –nut for attaching the magnetic unit

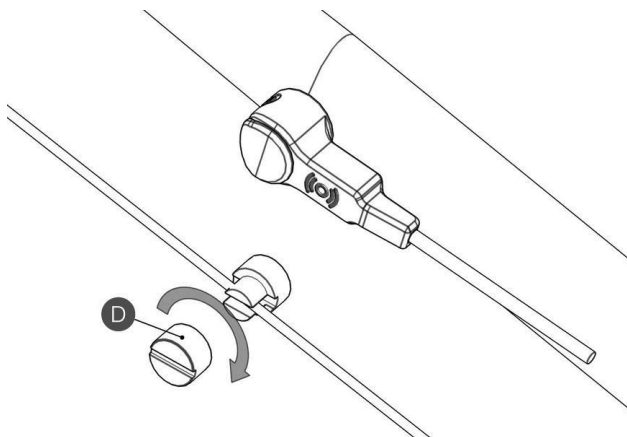

Tighten the nut D by a flat screwdriver.

Tightening torque: 1.5 –2 Nm

**Connector description:**

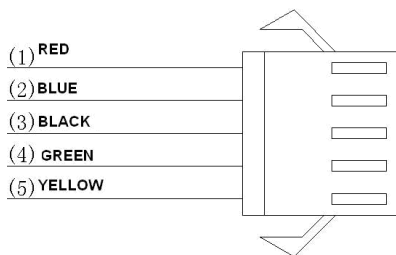

1 –Red wire: Anode (24V/36V)

2 –Blue wire: Power cord to the controller

3 –Black wire: GND

4 –Green wire: RxD (controller -display)

5 –Yellow wire: TxD (display -controller)

# Control

## Turning on the electrical system of the e-bike

Before switch on of the system please check electrical wiring.

Switch on display with press and short hold (1,5 second) POWER button. Display will automatically turns off if it is not used for a while. Can be set range 0 ~ 9 minutes (or OFF).

After ride turns off e-bike in the same way.

Press and hold UP button for turns on the display backlight.

For better gear change is appropriately stop pedaling for a while.

The illustrations used in this manual are set in the scenes setting ( Scenes - digital) as you can find in the manual below.

## Assist level operating

Short press UP/DOWN button can change the assist level. Top assist level is 5, 0 for neutral.

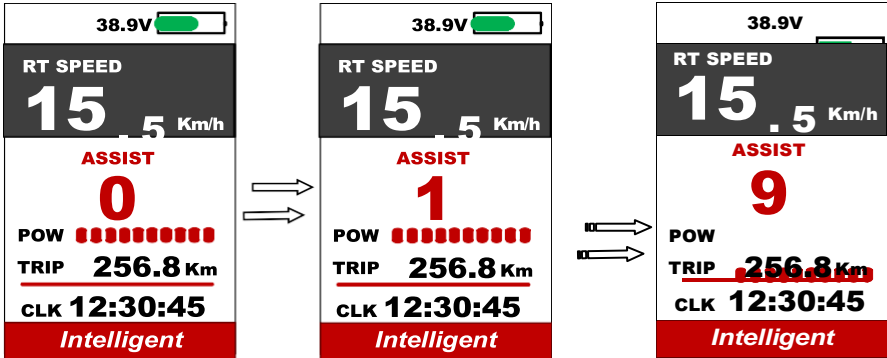

## Walking mode

Press and hold DOWN button for 2 second can get into walking mode, out of the mode when release the button.



### Speed and mileage mode switch

Short press POWER button can change the speed and mileage mode

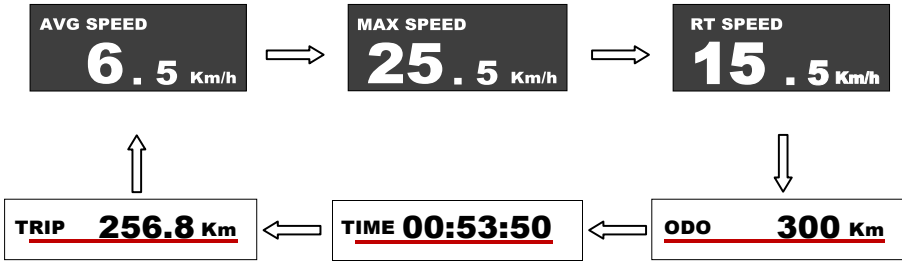

### Headlight/Backlight On/Off

Press and hold UP button for 1 second can turn on/off the headlight and the screen will switch to the corresponding mode.

The motor does not work when battery voltage is low. Display still can keep the headlight on for a while when e-bike is in riding.

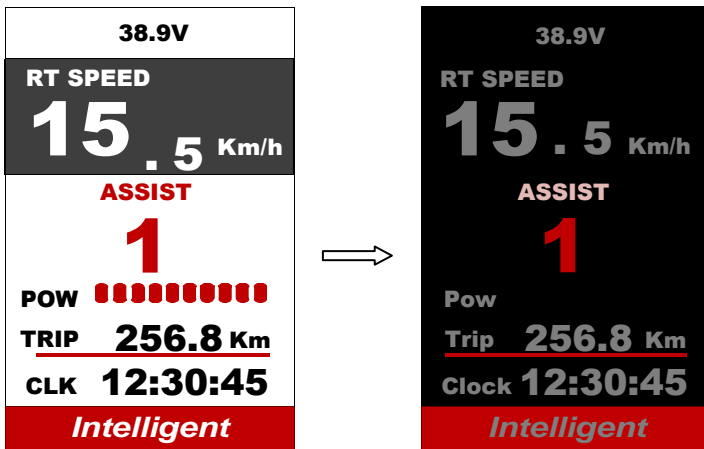

### Data cleanup

Press and hold UP and DOWN button together for 1 second can reset several temporary data, temporary data include AVG speed/MAX speed/Trip/Time.

## Parameter setting

By double press POWER button (interval less than 0,3 second) can get into setting menus.

Press UP/DOWN buttons to change the parameter setting, press POWER button to switch to next item.

Double press POWER button will exit from menu.

Display will automatically quit menu when there is no operation for 30 seconds.

For safety reasons, you can not enter the settings menu while riding.

## System (Km/mile)

Press UP/DOWN button to switch between Metric/Imperial.

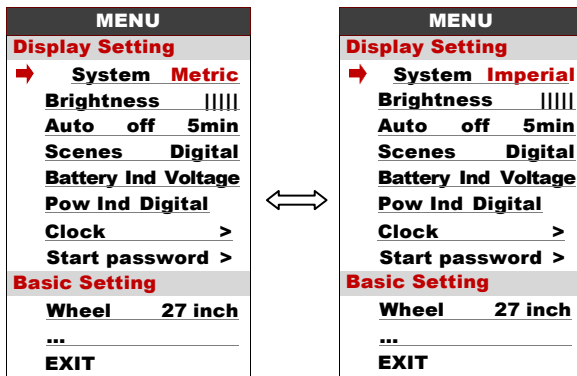

## Brightness

Press UP/DOWN button to change the brightness of the backlight, I is darkness, IIIII is brightness.

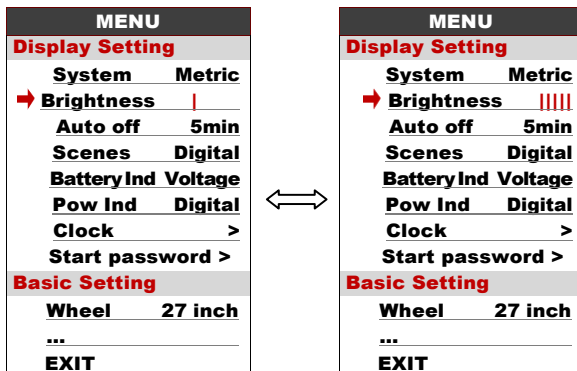

## Auto Off

Press UP/DOWN button to change the auto power off time, from 1 to 9 the number represent time (minutes) to shutdown, default value is 5 minutes.

MENU	
<b>Display Setting</b>	
System	Metric
Brightness	→
Auto off	<b>1min</b>
Scenes	Digital
BatteryInd	Voltage
Pow Ind	Digital
Clock	>
Start password	>
<b>Basic Setting</b>	
Wheel	27 inch
...	_____
EXIT	



MENU	
<b>Display Setting</b>	
System	Metric
Brightness	→
Auto off	<b>9min</b>
Scenes	Digital
BatteryInd	Voltage
Pow Ind	Digital
Clock	>
Start password	>
<b>Basic Setting</b>	
Wheel	27 inch
...	_____
EXIT	

## Scene

Press UP/DOWN button to change the scenes, Digital/Analog.

MENU	
<b>Display Setting</b>	
System	Metric
Brightness	
Auto off	5min →
Scenes	<b>Digital</b>
BatteryInd	Voltage
Pow Ind	Digital
Clock	>
Start password	>
<b>Basic Setting</b>	
Wheel	27 inch
...	_____
EXIT	



MENU	
<b>Display Setting</b>	
System	Metric
Brightness	
Auto off	5min →
Scenes	<b>Analog</b>
BatteryInd	Voltage
Pow Ind	Digital
Clock	>
Start password	>
<b>Basic Setting</b>	
Wheel	27 inch
...	_____
EXIT	

## Battery Ind

Press UP/DOWN button to change the battery indicator Voltage/Percentage/Off (napětí/kapacita v procentech/vypnuto).

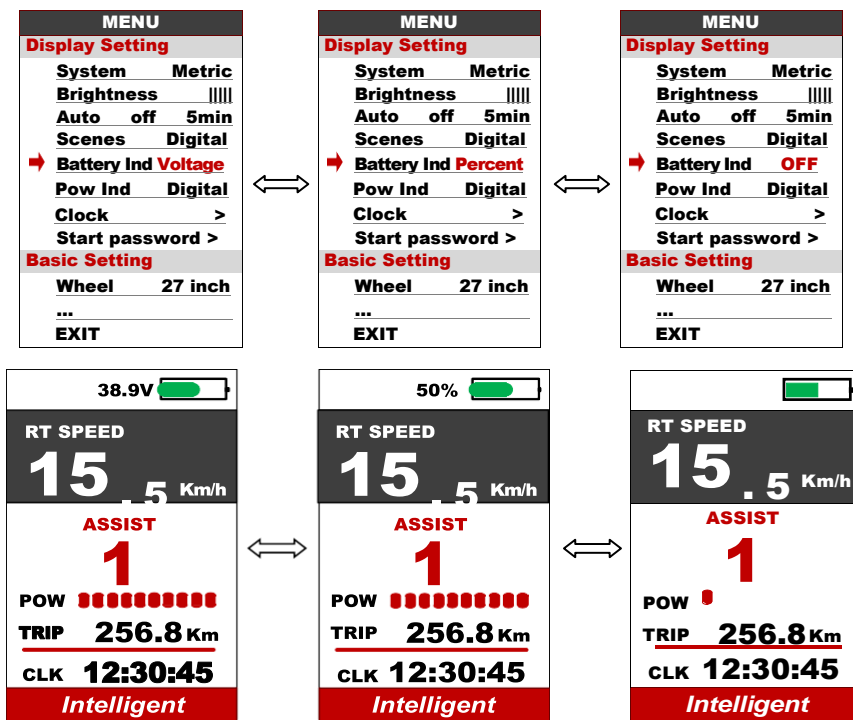

## Power indicator

Press UP/DOWN button to change the scenes, Digital/Analog.

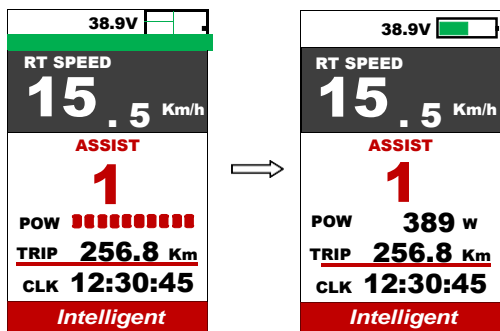

## Clock

Clock setting, press POWER button get into the clock setting menu, press UP/DOWN button to set Year/Month/Day/Hour/Min/Sec.

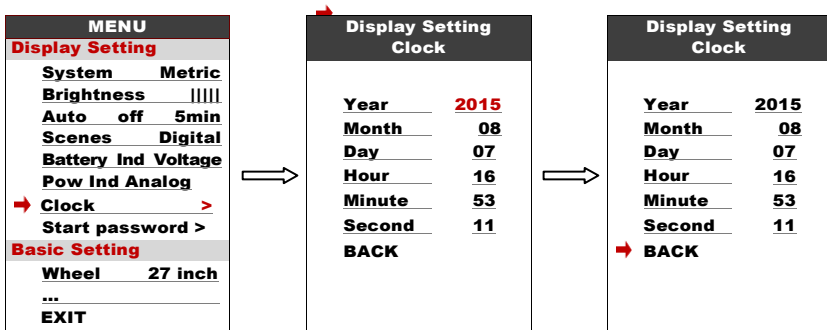

## Basic setting:

System is factory set. For changing these parameters contact your dealer or producer.  
Do not change these parameters by yourself, you can damage the e-bike.

Damaged caused by improper treatment is not within the scope of the warranty.

# Maintenance

## Regular maintenance:

- maintain all components of the electric bicycle clean
- use only the recommended and tested cleaning materials
- regularly lubricate the chain with suitable oils
- in winter, clean the electric bicycle after each ride and pay increased attention to removing salt from battery contacts and other connectors
- while handling the electric bicycle, make sure the cables of the electric system are not damaged. Damaged cables pose a risk of electricshock
- regularly check all connections for correct tightening and brakes for correct function. Check also individual parts of the electric bicycle for damage. For example: cracks on the frame, fork, handlebars, stem, damage to cables, damage to battery pack, etc.

## Battery transport:

Battery transport is subject to the requirements of regulations on dangerous goods. Private users may transport undamaged batteries on roads without having to conform to other conditions.

In case of transport by commercial users or by third parties it is necessary to comply with special packaging and marking requirements (e.g. ADR regulations)

Batteries should only be sent if the battery pack is undamaged. Plug loose contacts and pack the battery to prevent its movement in the packaging. Notify the forwarding service that the transport concerns dangerous goods.

## Battery storage:

Store the battery in a dry and well-ventilated place, out of reach of direct sunlight and other heat sources. In case of cold storage it is necessary to let the battery warm up to normal room temperature (20°C) before putting into operation.

Never leave the battery fully discharged. It could result in its permanent damage. For long-term storage keep the battery fully charged. However, do not store it while permanently connected to the charger or installed in the electric bicycle.

Li-Ion batteries are fully recyclable. After expiry of the battery life you can return it at any collection point or your dealer.

If you use an e-bike in hard conditions (long-term use of the maximum assistance), for longer ride at higher temperatures (30 ° C or above), in direct sunlight or when the battery is partially discharged and a combination of these situations is it possible that bike will automatically swith off. This is a fuse protecting the control unit against burning. We recommend stop the ride and let the bike (control unit) cool down little bit. This is not a defect.

# Possible problems and their solutions



In case of system failure perform its diagnostics or contact your dealer.

## **The control LCD display is not on:**

- always make sure the battery is charged
- check whether the battery is inserted correctly, whether the battery switch is on
- check the connections of the control unit and the display

## **The motor does not start when the walk assistance button is pressed**

- check the connection of the motor cable (at the motor and the control unit)
- check the connections of the control unit and the display

## **The motor does not start when rotating the pedal cranks (pedalling)**

- check the connection of the pedalling sensor to the control unit
- check the distance between the pedalling sensor and the magnet disk (max. 4 mm)
- check whether the disk is firmly attached to the central axle and does not spin freely
- in case of use of compact-type pedalling sensor

# Warning

In the event of system malfunction perform basic problem diagnostics, or have your electric bicycle checked by a specialized service place or contact your seller.

Do not attempt to repair the system yourself or tamper with its structure.

Error code	Error description	Solution
03	Brake error	Check the cable connection
04	Throttle position	Check the throttle position
05	Throttle error	Check throttle cable connection
06	Low voltage protection	Check battery voltage
07	High voltage protection	Check battery voltage
08	Motor cable error	Check motor and cable connection
09	Three-phase supply error	Check the three-phase electric line
11	Temperature sensor failure	Check controller
12	Actual fault of the sensor	Check controller
13	Battery temperature error	Check battery
21	Speed sensor failure	Zkontrolujte pozici snímače rychlosti
22	BMS Communication error	Change battery
30	Communication error	Check the controller connection



# Electric set warranty

## **Complaint procedure:**

Submit any complaints concerning the electric set or the battery to your dealer.

When filing a complaint, submit a proof of purchase and a warranty certificate with the registered serial number of the battery and indicate the reason for the complaint and a description of the defect.

## **Warranty conditions:**

24 months for electric bicycle components – applies to manufacturing and material defects beyond normal wear and tear caused by use.

12 months for battery life – the nominal battery capacity does not drop below 70% of the total capacity over 12 months from the sale of the electric bicycle.

## **Warranty conditions:**

The electric set must be used exclusively for the purposes it is intended for.

The electric set must be used, stored and maintained in accordance with these Operating Instructions.

## **A warranty claim shall expire:**

If it is found out that the damage to the product is due to the user's fault (accident, inexpert handling beyond the framework of these Operating Instructions, tampering with the structure of the electric bicycle or connection of the electric system, improper storage, etc.).

Expiry of the warranty period.

**The warranty only applies to the first owner**

# Warning

If you do not understand any of the points in these Operating Instructions, please contact the dealer for explanation. Please read the whole manual!

Do not lend the e-bike to persons not briefed in its use and operation. Complaints resulting from improper handling will not be accepted.

The LF Energy electric bicycle is not intended for use by children under 15 years of age. Likewise, the electric bicycle cannot be used by persons unable to pedal or handle it independently. The manufacturer is not to be held responsible for any potential injuries or damage to the bicycle!

Ideal weather conditions for using an electric bicycle are dry days, when the outdoor temperature is above 10°C. When used at lower temperatures, the battery discharges faster due to physical phenomena. Using the electric bicycle at temperatures below 0°C is not recommended.

Do not expose the bicycle to direct sunlight as it is fitted with a protective temperature sensor for the electric motor.

Never submerge the battery, the charger and other electric components in water or another liquid.

Never wash the electric bicycle in a pressure washer (WAP) and always remove the battery before washing

It is forbidden to tamper with the connections of the electric motor, the control unit and the battery. Violating this section may result in the warranty not being acknowledged or in irreversible damage to the electric bicycle.

**DO NOT USE** chargers and components other than the ones included with the electric bicycle.

We cannot be held responsible for damage caused by use of other non-approved goods.

# **LEADER FOX**



Enjoy many pleasant and safe kilometres on your new electric bicycle.

## **Your Leader Fox Team**



**Czech brand of electric bicycles.  
BOHEMIA BIKE**

**Address**  
Na Pankráci 1724  
14000 Praha 4 - Pankrác

**Development, design and manufacturing**  
Okružní 697  
České Budějovice 37004

Phone: 388 314 885  
Email: [info@leaderfox.cz](mailto:info@leaderfox.cz)

